

# Operation and Maintenance Manual

Helimotion Solar Tracking System  
Produced and assembled in the UK by  
Bee Solar Technology Ltd.

For more information or technical support

[www.beesolartech.co.uk](http://www.beesolartech.co.uk)

[sales@beesolartech.co.uk](mailto:sales@beesolartech.co.uk)



## ***ABOUT THIS MANUAL***

Congratulations on buying a Heliomotion product and on helping the environment by deciding to use renewable energy. This manual describes the installation, operation and maintenance of the Heliomotion Solar Tracker. Please read this manual carefully before installation, then store in a safe place for future reference.

## ***ABOUT THIS PRODUCT***

The core of the Heliomotion power plant is the dual-axis tracker. The tracker is designed to be mounted with either photovoltaic or thermal solar collectors and can carry a panel area of up to 10.7 m<sup>2</sup>.

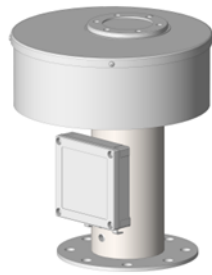

**Tracker**

There are four sizes: PV-2, PV-3, PV-4 and PV-6. These models use photovoltaic solar panels for power generation.



**PV-2**



**PV-3**



**PV-4**



**PV-6**

## INSTALLATION

The Heliomotion products are engineered to be easy to assemble and install. As such, the installation may be done by a DIY enthusiastic customer who has studied this manual, the quick assembly guide, and any other manuals provided for your specific solar system configuration. If you do not feel confident about doing the installation yourself, or if this is not legal in your country, we advise you to contact a qualified solar energy professional to perform the installation.



**IMPORTANT:** The electrical part of the installation must be carried out by a certified electrician. This requirement applies to the high voltage part of the system, including the solar panels and inverter along with their connections. It does not apply to turning on the tracker's power source, as this part of the system uses a low voltage.

For step by step instructions on how to perform the installation please refer to the quick assembly guide for your Heliomotion product. What follows here is complementary information to that document.

### Site selection

The solar power plant is typically installed free standing on the ground. The key to site selection is to choose a sunny location that has a clear view of the sun's path from sunrise to sunset, or as much of the path as possible, to provide the maximal amount of energy. In this way you will gain the most from your installation. The tracker rotates, therefore it should be situated away from obstructions and vegetation that may come in contact with it during this movement. The minimum clearance from the foundation column is 1 meter for a PV-2, 1.3 meter for a PV-3, 1.5 meter for a PV-4 and 2 meter for a PV-6.

### Extension column

Typically, the tracker is installed on an included 1.5 meter extension column. It is recommended that the installation height does not exceed this length, in order to make assembly simple.

### Wiring

An installation with a 1-phase grid-tied inverter mounted on the unit needs a cable with 3 cores. Other installations, such as battery systems and 3-phase grid-tied systems, require a cable with 5 cores. The cable needs to be shielded and suitable for underground use. Subject to local regulations, the cross sectional area of the wire is recommended to be 6 mm<sup>2</sup> for cable runs up to 100 meters. Note that using a 5-core cable makes it easier to upgrade a 1-phase system into a 3-phase system at a later date.

The cable size can be adjusted to keep transmission losses low between the power plant and the inverter/solar station. Correct sizing of wires is important for both safety and energy efficiency. Undersized wires cause high energy loss (voltage drop) to the system, and if substantially undersized may lead to electrical fire.

### Power options

The tracker can be powered from any constant 24 VDC power source – either from a 24 V battery bank or from the grid using a 24 VDC transformer. If the installation is for a 48-volt battery system the tracker can be powered from any 24 VDC point in the battery array, due to its low power consumption. The input voltage range is 24 VDC  $\pm$  20%.

### **Commissioning**

Commissioning of a PV system, including connecting the electrical wires from the solar panels and switching on the AC and DC breakers to the inverter or solar station, must be performed by a certified electrician.

## **MAINTENANCE**

The Heliomotion Tracker has been designed to run for long periods without requiring any maintenance. There are no parts that require scheduled maintenance procedures.

It is recommended that you visually inspect your system annually. This includes checking that all bolted joints are tight and making sure the panels are clean in order to maintain maximum power output.

### **Serviceable components**

This product has been designed to allow worn out components to be replaced by the customer as needed. Through this process the lifetime of the system can be greatly extended. Visit the following page to determine what component to repair or replace.

- <https://heliomotion.com/support>

## **OPERATION**

The operation of your tracker is fully automatic and it will start tracking the sun as soon as you connect power to it. When powered on the tracker goes through the following steps:

1. The tracker waits until a GPS fix has been established to retrieve information needed to calculate the sun's current position: latitude, longitude, date and time. This information is recalibrated every morning.
2. The tracker rotates to face the sun's present position.
3. As the sun moves across the sky the tracker follows it, moving in intervals of 1.8 degrees every couple of minutes. After each movement the tracker positions itself 0.9 degrees ahead of the sun.
4. The tracker continues to follow the sun until sunset or until its evening position is reached, which is 90 degrees after the noon position.
5. After sunset the tracker returns to its noon position.
6. Before sunrise the tracker moves to sunrise position or to morning position, which is 90 degrees before the noon position.
7. The tracker awaits sunrise and then repeats the sequence from Step 4.

### **Safety and obstacle handling**

It is important to keep the tracker's path clear of obstacles, such as vegetation and snow. If the tracker encounters an obstacle that prevents it from rotating the tracker will pause its normal operation for an hour before trying to rotate again. The motor power is set to a low value (5 Nm) by default for safety reasons, allowing a person or obstacle to easily stop the rotation of the tracker without causing damage to the installation or injuries to any person. The default rotation speed is also set low (5 minutes for 180 degrees) for safety reasons. Parameters such as motor torque, motor speed and pause duration can be adjusted using the Heliocom software.

### **Internal clock**

As a redundancy feature the tracker is equipped with an internal clock which has a replaceable backup battery (3V lithium cell). Should the GPS module or GPS network fail the tracker can still keep operating for many years using this clock and the stored latitude/longitude settings. Note that the tracker operates on solar time, which is different from local time. The sun always reaches its highest elevation at 12:00 solar time.

## **USB INTERFACE**

For service purposes the tool Heliocom can be used to communicate with the tracker. The tool and its description can be found from the link below under the Using Heliocom section:

- <https://heliomotion.com/support>

A USB connector is found on the circuit board on the solar tracker. By connecting to this terminal with a Windows laptop and a USB extension cable, Heliocom allows the following tasks to be performed:

1. Manual control of the tracker. Specifically, turning the tracker clockwise, counter-clockwise, stopping its movement, resuming its movement and resetting the unit.
2. Changing configurable settings – such as motor torque and rotation speed.
3. Monitoring the tracker's operation.

## **LEDs**

The circuit board has five LEDs that indicate the status of the tracker:

- (A) Green – Blinks to indicate that the tracker is powered and operational.
- (B) Yellow – Lit if the tracker has paused its operation due to being unable to rotate. Blinks to indicate movement to either start or noon position.
- (C) Orange – Lit to indicate temperature alarm (for thermal installations). Blinks instead of green LED to indicate the clock battery is depleted.
- (D) Blue – Lit during GPS synchronization, which occurs at startup and dawn.
- (E) Red – Lit to indicate satellites were not found during the latest GPS synchronization.

A second set of two LEDs are found near the bottom of the circuit board: red and orange. The orange led is lit while the motor is running. The red led is not used.

## **WORKING ENVIRONMENTS**

The Heliomotion Tracker is designed to operate in most geographical areas and climate conditions. The standard (dual-axis) configuration can be deployed in locations situated between 20° and 70° on the northern or southern hemisphere

### **Snowy regions**

The foundation column length is chosen to prevent the tracker from getting stuck in the snow during winter. Should the snow depth surpass 0.5 meters the snow should be manually removed around the Heliomotion's path. Snow prevents light from getting through to the solar panels, but as soon as the sun hits the panels they are usually the first place to become snow free. Since the panels are at a steep angle in the tracker's morning and evening positions, most snow falls right off the unit and there is usually no need to remove the snow manually.

### **Dry regions**

Solar arrays are typically self-cleaned by the rain and do not need additional cleaning. However, in dry regions it may be necessary to wash the panels every couple of months to prevent dust and sand from building up.

### **Windy regions**

The largest PV-6 unit is engineered to withstand wind speeds up to 35 m/s. Should wind speeds above 30 m/s be expected, it is recommended that you use the provided extension rod to tilt the panels horizontally and that you turn off the tracker (preferably near noon position). This will reduce wear and protect the installation until the storm has passed, as this is the optimum position for the installation to resist high wind loads. Be sure to secure the M16 coupling nut by tightening it against the regular M16 nut illustrated below. Do not attempt to attach the extension rod if it's already windy outside.

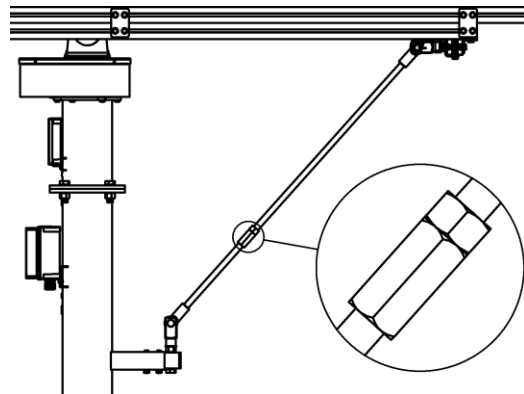

## **WARRANTY**

Subject to the terms below, Bee Solar Technology Ltd guarantees its own products against defects in material or workmanship under normal use consistent with product instructions for a period of 5 years from the original date of purchase. If warranted products contain defects covered under this warranty, Bee Solar Tech's obligation shall be limited to, in their sole and absolute discretion, repairing or replacing the defective parts. Repaired or replaced parts are warranted for the remainder of the original warranty period. This limited warranty does not cover:

- Equipments, materials, or supplies not manufactured by Bee Solar Technology Ltd
- Products that has been modified or altered with non-original parts.
- Damage due to wind speeds over 35 m/s (80 MPH).
- Damage due to severe weather conditions, such as excessive wind, hail, ice, lightning strikes or other natural occurrences.
- Accidental or intentional damage.
- Damage due to improper installation.
- Misuse, abuse, or neglect.
- Products used for purposes other than their intended use.
- Trackers with more than the intended area of panels mounted on them.
- Damage due to improper packaging on return shipment.

Any and all labour charges for troubleshooting, removal or replacement of solar power plant or components of solar power plant are not covered by this warranty. Return shipping is to be pre-paid by the original purchaser.

## TECHNICAL SPECIFICATIONS

<b>Mechanical capabilities</b>	
Number of turning axis	Dual-axis (with single motor)
Protection rating	IP65 (designed for outdoor installation)
Azimuth tracking	180°
Elevation angle	20-90°
<b>Tracker specific properties</b>	
Weight (ex. packaging)	24 kg
Dimensions	315x315x370 mm
Max panel area	10.7 m <sup>2</sup> (6x 1.7x1 meters solar panels)
Max panel weight	140 kg
<b>Environmental data</b>	
Ambient temperature	-25 °C to +55 °C
Height	0m to 2000m above mean sea level (AMSL)
Operating humidity	0% to 100% of relative humidity
Max safe wind speed	30 m/s
<b>Electrical data</b>	
Operational voltage	10-29 VDC
Motor current capacity	1000 mA default, configurable up to 2000 mA
Power consumption	<0.3 watt while idle, 25 watt while moving
Energy consumption	<0.01 kWh/day
Backup battery	CR927 3V cell, compliant with IEC 60086-4
Communication interface	USB
<b>Positioning data</b>	
Accuracy of tracking	±0.9°
Turning interval	1.8° (~7 min)
<b>Standards</b>	
In compliance with	CE, EN 301489-1, EN 301489-19